

REFERENCES

- [1] G. S. Moschytz, "Active RC filter building blocks using frequency emphasizing networks," *IEEE J. Solid-State Circuits*, pp. 59-62, June 1967.
- [2] S. K. Mitra, *Analysis and Synthesis of Linear Active Networks*. New York: Wiley, 1969, pp. 161-207.
- [3] A. G. J. Holt and M. R. Lee, "Sensitivity comparison of active-cascade and inductance simulation schemes," *Proc. Inst. Elec. Eng.*, vol. 119, pp. 277-282, Mar. 1972.
- [4] R. A. Friederson, "Computer-aided design of practical RC active filters," presented at the 1972 IEEE Int. Symp. Circuit Theory, North Hollywood, Calif., Apr. 1972.
- [5] R. L. Adams, "On reduced sensitivity active filters," in *Proc. 14th Midwest Symp. Circuit Theory*, pp. 14.3-1-14.3-8.
- [6] J. Tow and Y. L. Kuo, "Coupled-biquad active filters," presented at the 1972 IEEE Int. Symp. Circuit Theory, North Hollywood, Calif., Apr. 1972.
- [7] W. J. Kerwin, L. P. Huelsman, and R. W. Newcomb, "State variable synthesis for insensitive integrated circuit transfer functions," *IEEE J. Solid State Circuits*, pp. 114-116, Sept. 1967.
- [8] J. Tow, "Active RC filters—A state-space realization," *Proc. IEEE*, pp. 1137-1139, June 1968.
- [9] —, "Design formulas for active RC filters using operational amplifier," *Electron. Lett.*, pp. 339-341, July 24, 1967.
- [10] D. Akerberg and K. Mossberg, "Low-sensitivity easily trimmed standard building block for active RC filters," *Electron. Lett.*, pp. 528-529, Oct. 16, 1969.
- [11] L. C. Thomas, "The biquad: Part I—Some practical design considerations," *IEEE Trans. Circuit Theory*, vol. CT-18, pp. 350-357, May 1971.
- [12] —, "The biquad: Part II—A multipurpose active filtering system," *IEEE Trans. Circuit Theory*, vol. CT-18, pp. 358-361, May 1971.
- [13] A. G. J. Holt and J. I. Sewell, "Active RC filter—Employing a single operational amplifier to obtain biquadratic responses," *Proc. Inst. Elec. Eng.*, pp. 2227-2234, Dec. 1965.
- [14] T. A. Hamilton and A. S. Sedra, "A single-amplifier biquad active filter," *IEEE Trans. Circuit Theory*, vol. CT-19, pp. 398-403, July 1972.
- [15] M. A. Soderstrand, "Sensitivity studies of multi loop active RC filters," M.S. thesis, Univ. of California, Davis, Sept. 1969.
- [16] N. Fliege, "Complementary transform of feedback systems," in *Proc. IEEE 1972 Int. Symp. Circuit Theory* (North Hollywood, Calif.), pp. 61-65, Apr. 1972.
- [17] P. R. Geffe, "A Q -invariant active resonator," *Proc. IEEE (Lett.)*, p. 1442, Aug. 1969.
- [18] M. A. Soderstrand and S. K. Mitra, "Very low sensitivity canonic active RC filter," *Proc. IEEE (Lett.)*, pp. 2175-2176, Dec. 1969.
- [19] —, "Sensitivity analysis of third-order filters," *Int. J. Electron.*, pp. 265-272, Mar. 1971.
- [20] —, "Gain and sensitivity limitations of active RC filters," *IEEE Trans. Circuit Theory (Special Issue on Active and Digital Networks)*, vol. CT-18, pp. 600-609, Nov. 1971.

Tunable RC -Active Filters Using Periodically Switched Conductances

L. T. BRUTON AND ROGER T. PEDERSON

Abstract—The realization of electronically tunable RC -active filters is achieved by the use of periodically switched conductances within the filter. A method of analysis of RC networks containing periodically switched conductances is given, which is based on the impulse response of the network at a capacitance. The use of periodically switched conductances to tune RC -active filters has several practical advantages, such as eliminating the need to carefully match independently adjustable network elements and being able to control a transfer function with one timing waveform. This method of electronically tuning RC -active filters is illustrated by several designs.

I. INTRODUCTION

IN RECENT years, tunable filters have come to play an ever increasing role in signal processing. Tunable active filters have found applications in such areas as the analysis of seismic data and adaptive filtering of signals from noisy communication channels. In realizing a tunable filter, one or more elements must be varied

in order to vary the frequency response of the filter. Elements such as resistors and low-valued capacitors can be varied mechanically or by using specialized devices such as varistors and varicap diodes. These methods present practical problems, especially where high accuracy is important.

Tunable system functions have been realized by using several techniques such as the N -path filter approach [1], switched capacitor network [2], and resonant transfer circuits. Several authors [3]–[5] have proposed methods of electronically tuning a filter transfer function by periodically switching network elements. The coefficients of the transfer function become functions of the pulsewidth-to-period ratio of the switched elements. Edwards [3] and Kaehler [4] have applied this method to first-order RC networks in which the cutoff frequency of the RC filter was tuned by varying the pulsewidth-to-period ratio of the switched resistances. Girling and Good [5] have shown that this technique can be used to tune the cutoff frequency and/or bandwidth of higher order active filters, and it has been shown that impedance scaling, using analog multipliers,

can be used to electronically tune RC -active filter structures [4], [6].

Networks containing periodically switched elements have been analyzed by several methods. Desoer [7] has given a systematic method of analyzing a linear network containing a switch by using Bashkow's [8] "A-matrix" formulation of network equations. The state-space approach has been used by Sun and Frisch [9] to analyze networks containing periodically switched conductances and Kaehler [4] has used the difference equation approach to analyze simple RC networks. These methods tend to require a great deal of algebraic manipulation, especially for higher order systems.

It is our aim to present a relatively simple method of analysis of RC -active networks containing periodically switched conductances and to apply this method to the frequency scaling of network functions. The proposed method is based on the evaluation of the response of a capacitance voltage to the application of an impulse $\delta(t)$ at the input port of the network. It is shown that by using periodically switched conductances, this impulse response can be amplitude and time scaled; hence the transfer function can be frequency scaled.

If the output voltage of the network is not available across a capacitance element, then, in general, the required frequency scaling does not occur. For example, the class of high-quality RC -active ladder realizations often consist of an active network embedded between *resistive* terminations and it will be shown that the periodically switched conductance approach does not always achieve frequency scaling. Two methods are proposed for achieving switched-conductance frequency scaling. The first is to scale all branch admittances by s such that the output appears across a capacitance [10]. The second method requires the addition of a low-pass filter at the output which effectively places the new output across a capacitance.

An active filter realization which is to be frequency scaled by periodically switched conductances should be a low-sensitivity structure in order to avoid the problem of small errors in the switched conductances causing large errors in the network function. For this reason, equiterminated RC -active *ladder* structures [11] have been chosen to realize frequency-scaled network functions using periodically switched conductances. Two approaches have been described for the design of RC -active ladder filters: the inductance simulation approach [11]–[13] and the DCR [10] ladder networks.

II. FREQUENCY-SCALING NETWORK FUNCTIONS

A. Frequency Scaling Using Continuously Variable Conductances

There are many RC -active realizations in which the transfer function may be continuously frequency scaled by means of a set of continuously variable conductances. This conductance set will be denoted by $KG_1 \cdots KG_N$, where K is a dimensionless variable,

hereafter referred to as the scaling factor. In some networks it is not difficult to identify $KG_1 \cdots KG_N$ by inspection. However, the general problem of identifying them is as follows. Frequency scaling a transfer function $\Lambda(s)$ to give a scaled transfer function $\Lambda(s/K)$ requires that

$$\Lambda\left(\frac{s}{K}\right) = \frac{\sum_{i=0}^q b_i \left(\frac{s}{K}\right)^i}{\sum_{j=0}^p a_j \left(\frac{s}{K}\right)^j} \quad (1)$$

where K is the scaling factor. In general, the corresponding impulse response $\lambda(t)$ must be of the form

$$\lambda(t) = K \sum_{j=0}^p m_j e^{n_j K t} \quad (2)$$

where the coefficients a_j , b_i , m_j , and n_j are independent of K . The conductance set $KG_1 \cdots KG_N$ is chosen such that (1) [and hence (2)] is satisfied. We assume that $KG_1 \cdots KG_N$ is identified and wish to consider the effect on the transfer function of periodically switching each of these conductances such that K is a discontinuous discrete periodic time function $K(t)$ with average value \mathbf{K} .

B. Frequency Scaling Using Periodically Switched Conductances

Consider the conductance set to be periodically switched such that they are given by $K(t)G_1 \cdots K(t)G_N$, where

$$\begin{aligned} K(t) = & K_1[u(t - nT) - u(t - nT - \tau)] \\ & + K_2[u(t - nT - \tau) - u(t - (n+1)T)], \\ & n = -\infty \cdots \infty. \end{aligned} \quad (3)$$

A sketch of $K(t)$ is given in Fig. 1(a) and it is easily shown that

$$\mathbf{K} = \frac{K_1}{T} \left[\tau + \frac{K_2}{K_1} (T - \tau) \right]. \quad (4)$$

We define two impulse responses of the time-invariant (i.e., unswitched) version of Fig. 1(b), given by

$$\lambda_{c1}(t) = K_1 \lambda_c(K_1 t), \quad K(t) = K_1$$

and

$$\lambda_{c2}(t) = K_2 \lambda_c(K_2 t), \quad K(t) = K_2 \quad (5)$$

where we constrain the *output voltage to be across a capacitance* within the network as shown in Fig. 1(b).

The impulse response of a time-invariant system containing conductances $KG_1 \cdots KG_N$ is defined as $\lambda_c(t)$. Thus

$$\lambda_c(t) = \mathbf{K} \lambda_c(\mathbf{K}t). \quad (6)$$

We have so far defined impulse responses of the *time-invariant* systems. The impulse response of the time-varying system with conductance $K(t)G_1 \cdots K(t)G_N$ is defined as $h_c(t, T)$. We wish to prove that

$$\lim_{T \rightarrow 0} h_c(t, T) = \mathbf{K} \lambda_c(\mathbf{K}t) \quad (7)$$

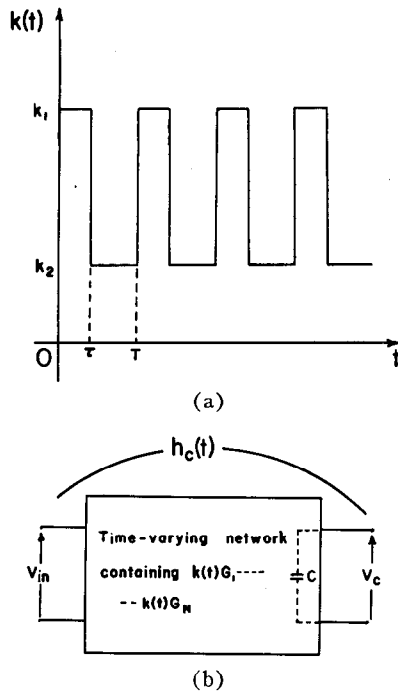

Fig. 1. (a) Time variation of switched conductances. (b) Time-varying RC-active network.

where there is an implied functional dependence of $h_c(t, T)$ on τ and $\tau < T$.

Proof: Consider finite T such that $\lambda_{c1}(t)$ and $\lambda_{c2}(t)$ are accurately represented by a piecewise linear approximation obtained by interconnecting samples $\lambda_{c1}(nT)$ and $\lambda_{c2}(nT)$ as shown in Fig. 2(a). Note that we wish to prove that a piecewise linear curve $h_c(t, T)$ corresponding to Fig. 1(b) will approximate to the curve $K\lambda_c(Kt)$ that is sketched in Fig. 2(a).

At time $t=0^+$, immediately after the application of $\delta(t)$ to the input of Fig. 1(b), $K(t)=K_1$. Thus for $0 < t < \tau$, $h_c(t, T) = \lambda_{c1}(t)$. Since we can represent $\lambda_{c1}(t)$ by a piecewise linear approximation, then the point A in Fig. 2(a) is given by

$$h_c(\tau, T) = \lambda_{c1}'(0)\tau \tag{8}$$

During time $\tau < t < T$, the conductance set becomes $K_2G_1 \cdots K_2G_N$ and it is necessary to evaluate $h_c(t, T)$ during this time.

$\tau < t < T$

At point A, or time τ on the $h_c(t, T)$ curve, we know that $K(t)$ changes instantly from K_1 to K_2 . However, since $V_c(t)$ is across a capacitor, it cannot change instantaneously. Thus at time τ^+ , immediately after switching, $h_c(\tau^+, T)$ is equal to $\lambda_{c1}'(0)\tau$. However, we now require the new slope of $h_c(t, T)$ during the time $\tau < t < T$. The initial conditions of the network at time τ^+ are uniquely defined by the capacitance voltages. This same set of capacitance voltages could have been obtained at time $(K_1/K_2)\tau$ as follows: By applying an impulse $(K_1/K_2)\delta(t)$ to the unswitched network given

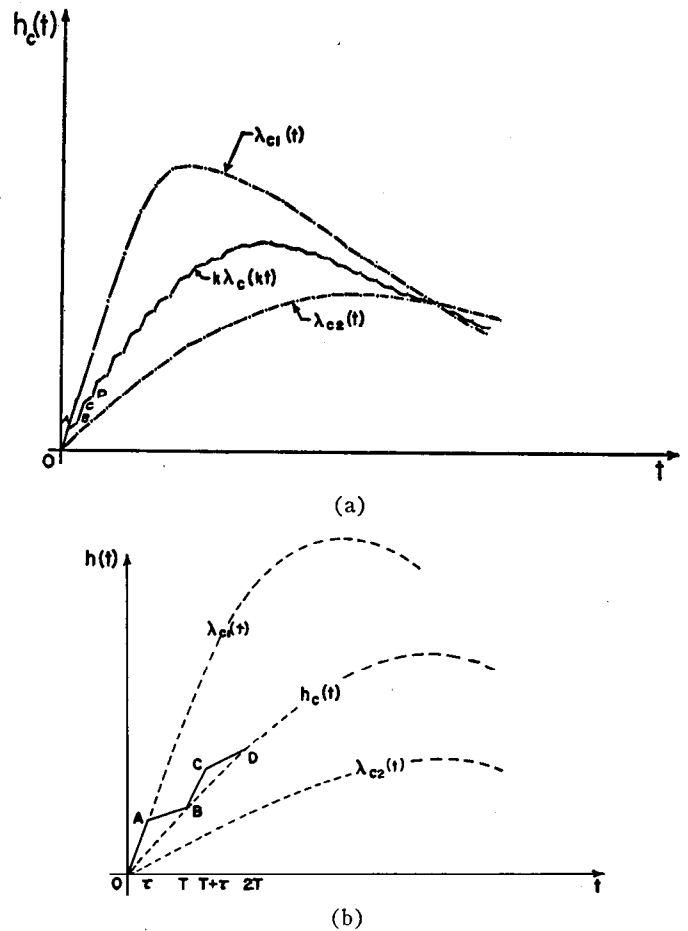

Fig. 2. (a) Impulse responses of RC-active network. (b) Impulse response during the first two periods of $K(t)$.

by $K(t) = K_2$. This would result in a scaled impulse response of the form $K_1\lambda_c(K_2t)$ [a time-scaled version of $K_1\lambda_c(K_1t)$] and the derivative of this curve at time $(K_1/K_2)\tau$ is given by $(K_2/K_1)\lambda_{c1}'(0)$. Thus the slope AB is given by $(K_2/K_1)\lambda_{c1}'(0)$ and we conclude that we can find $h_c(T)$ by vector addition of \vec{OA} and \vec{AB} . This is shown schematically in Fig. 2(b). Vector addition gives

$$h_c(T, T) = \lambda_{c1}'(0)\tau + (T - \tau) \frac{K_2}{K_1} \lambda_{c1}'(0) \tag{9}$$

which results in an average slope for the time $0 < t < T$ of

$$h_c'(0, T) = \frac{\tau\lambda_{c1}'(0) + (T - \tau) \frac{K_2}{K_1} \lambda_{c1}'(0)}{T} = \lambda_{c1}'(0) \left[\frac{\tau + (T - \tau) \frac{K_2}{K_1}}{T} \right] \tag{10}$$

Now

$$\lambda_{c1}'(0) = K_1 \left. \frac{d}{dt} \lambda_c(K_1t) \right|_{t=0} = K_1\lambda_c'(0) \tag{11}$$

Thus (10) can be written in the form

$$h_c'(0, T) = \lambda_c'(0) \frac{K_1}{T} \left[\tau + (T - \tau) \frac{K_2}{K_1} \right] \quad (12)$$

and substituting (4) into (12) gives

$$h_c'(0, T) = K\lambda_c'(0). \quad (13)$$

The value of $h_c(T, T)$ in terms of the slope $h_c'(0)$ is given by

$$h_c(T, T) = Th_c'(0, T) = TK\lambda_c'(0) \quad (14)$$

which can be rewritten as

$$h_c(T, T) = K\lambda_c(KT). \quad (15)$$

Consider now the next time period $T < t < T + \tau$ in which the conductance set becomes $K_1G_1 \cdots K_1G_N$.

$T < t < T + \tau$

At point B on the $h_c(t, T)$ curve, $K(t)$ switches instantly from K_2 to K_1 . Since $h_c(t, T)$ is across a capacitor as described previously, $h_c(T^+, T) = K\lambda_c(KT)$. We now need the slope of $h_c(t)$ during the time $T < t < T - \tau$. The capacitances in the network define the initial conditions as described for the switching $t = \tau$. The unswitched network with $K(t) = K_1$ would have the same set of capacitance voltages at time $(K/K_1)T$ if an impulse of amplitude $(K/K_1)\delta(t)$ had been applied at $t = 0$ to the network having the conductance set $K_1G_1 \cdots K_1G_N$. This would again result in a scaled impulse response of the form $K\lambda_c(K_1t)$ with a derivative at time $(K/K_1)T$ of

$$K\lambda_c'(K_1t) \Big|_{t=(K/K_1)T}.$$

The slope BC is then given by

$$K\lambda_c'(K_1t) \Big|_{t=KT/K_1}.$$

$T + \tau < t < 2T$

At time $T + \tau$ or point C , $K(t)$ again changes instantly from K_1 to K_2 . Since the impulse responses are assumed piecewise linear, the slope at $(T + \tau)^+$ is defined for $K(t) = K_2$ at $t = T$. Following the previous discussion, the network has the same capacitance voltages at $t = (K/K_2)T$ as if an impulse of value $(K/K_2)\delta(t)$ is applied at $t = 0$. This gives a scaled impulse response of $K\lambda_c(K_2t)$ having a derivative at $t = (K/K_2)T$ of

$$K\lambda_c'(K_2t) \Big|_{t=(K/K_2)T}.$$

The slope of $h_c(t)$ during interval $T + \tau < t < 2T$ is

$$CD = K\lambda_c'(K_2t) \Big|_{t=(K/K_2)T}.$$

The value of $h_c(2T)$ is then given by the vector addition of \vec{BC} and \vec{CD} and the value of $t = T$ to yield

$$h_c(2T, T) = h_c(T, T) + \tau K\lambda_c'(K_1t) \Big|_{t=(K/K_1)T} + (T - \tau) K\lambda_c'(K_2t) \Big|_{t=(K/K_1)T}. \quad (16)$$

Now the slopes BC and CD are simple related by

$$K\lambda_c'(K_2t) \Big|_{t=(K/K_2)T} = \frac{K_2}{K_1} K\lambda_c'(K_1t) \Big|_{t=KT/K_1} \quad (17)$$

because the values of the impulse responses at the times given in (17) are equal. Using (17), the average slope BD can be evaluated as follows:

$$h_c(T, T) = \frac{1}{T} \left[\tau K\lambda_c'(K_1t) \Big|_{t=(K/K_1)T} + (T - \tau) K \frac{K_2}{K_1} \lambda_{c1}'(K_1t) \Big|_{t=(K/K_1)T} \right] \quad (18)$$

$$h_c'(T, T) = K\lambda_c'(K_1t) \Big|_{t=(K/K_1)T} \left[\frac{\tau + (T - \tau) \frac{K_2}{K_1}}{T} \right]. \quad (19)$$

The derivative of $\lambda_c(K_1t)$ evaluated at $t = (K/K_1)T$ takes the form $K_1\lambda_c'(KT)$, where the constant K_1 is a result of the differentiation with respect to t and has been moved outside the derivative $\lambda'(KT)$. Thus (19) can be rewritten in the form

$$h_c'(T, T) = K^2\lambda_c'(KT) \quad (20)$$

which represents the derivative of a continuous impulse response $K\lambda_c(Kt)$ evaluated at $t = T$, where the constant K caused by differentiation has been removed from $\lambda_c'(Kt)$. This means that at point D , the response is on the desired average response $K\lambda_c(Kt)$. Now, it has been shown that the impulse response $h_c(t, T)$ lies on the curve $K\lambda_c(Kt)$ at times $0, T$, and $2T$. The argument can be continued indefinitely to show that, at all successive times nT , the response $h_c(t, T)$ is on the required continuous average curve given by the unswitched conductance set $KG_1 \cdots KG_N$. Thus (5) is valid and the proof is complete. *The implication of the proof is important because it follows that (1) and (2) are sufficient to describe the network transfer function if the output voltage is across a capacitor and if the impulse responses $\lambda_{c1}(t)$ and $\lambda_{c2}(t)$ are accurately represented by the piecewise linear approximation.* This latter constraint implies a maximum bandwidth limitation on $|H_c(j\omega)|$ and does not allow discontinuities in $\lambda_{c1}(t)$ and $\lambda_{c2}(t)$. Clearly the switching frequency $1/T$ must be as high as possible. Having proved the validity of (7), we assume in subsequent sections that $h_c(t, T)$ has arbitrarily small T and may be written as $h_c(t)$. If the discontinuity in $K(t)$ does not coincide with the application of the impulse $\delta(t)$, a more complex proof is necessary.

C. Noncapacitance Output Voltage

The analysis thus far has required the output to be across a capacitance. If a periodically switched RC-active network does not satisfy this constraint, we must consider other possibilities for obtaining a frequency-scaled network response. One method is to add a low-

TABLE I
GIC REALIZING FREQUENCY-SCALED IMPEDANCES

	Z_1	Z_2	Z_3	Z_4	Non-Switched Impedance	Switched Conductance	Frequency-Scaled Impedance as Proved in Section II
Capacitive Impedance	G_1	G_2	$\frac{1}{sC_3}$	G_4	$\frac{G_2G_4}{sC_3G_1G_5}$	$K(t)G_2$ or $K(t)G_4$	$\frac{KG_2G_4}{sC_3G_1G_5}$
Inductive Impedance	G_1	$\frac{1}{sC_2}$	G_3	G_4	$\frac{sC_2G_4}{G_1G_3G_5}$	$K(t)G_1$ or $K(t)G_3$	$\frac{sC_2G_4}{KG_1G_3G_5}$
FDNR	$\frac{1}{sC_1}$	G_2	$\frac{1}{sC_3}$	G_4	$\frac{G_2G_4}{s^2C_1C_3G_5}$	$K(t)G_2$ and $K(t)G_4$	$\frac{K^2G_2G_4}{s^2C_1C_3G_5}$

Note: $I_2(s)/V_2(s) = G_5$.

pass filter at the output of the network such that the new output appears across a capacitance and the constraints of the proof are satisfied.

III. REALIZATION OF ELECTRONICALLY TUNABLE ACTIVE FILTERS

In making an electronically tunable active filter, a choice must be made as to which RC -active filter structure should be used. RC -active equiterminated ladder structures have successfully been used to realize high-quality transfer functions. Several approaches have been used, namely the inductive simulation approach [12], [13], [15], [16], and impedance scaling an LCR ladder network to a topologically similar DCR [10] ladder network having the same voltage transfer function.

Two realizations of RC -active ladder structure have been described; consider now how these structures can be used to realize tunable active filters. A tuned or frequency-scaled version of an LCR - or simulated LCR -active ladder filter has a transfer function of the form

$$T_{LCR}\left(\frac{s}{K}\right) = T_{LCR}\left(\frac{sL_i}{K}, \frac{K}{sC_i}, R_i\right) \quad (21)$$

where K is the scaling parameter. In a similar fashion, a tunable DCR ladder filter has a transfer function of the form [6]

$$T_{DCR}\left(\frac{s}{K}\right) = T_{DCR}\left(\frac{K^2}{s^2D_i}, \frac{K}{sC_i}, R_i\right). \quad (22)$$

It is noted that the frequency-scaling parameter K^2 appears with the D element, and thus the D element must be scaled by K^2 to achieve frequency scaling of the transfer function. In (21) and (22) the frequency scaling of the transfer function is achieved by frequency scaling the frequency-dependent elements. The question now arises as to how periodically switched conductances can be used to frequency scale the network elements. The inductances, capacitances, and frequency-dependent negative-resistance (FDNR) or D elements can all be realized by generalized impedance converters (GIC's), and thus methods of frequency scaling the input impedance of the GIC's are now considered.

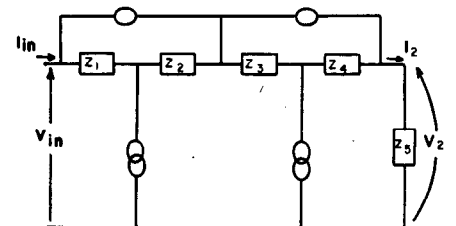

(a)

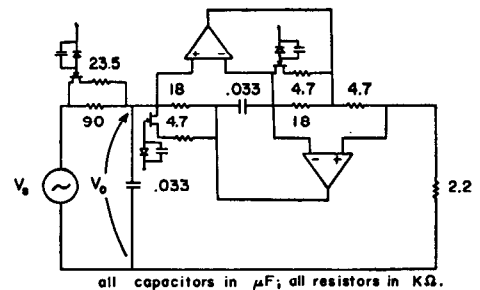

(b)

Fig. 3. (a) GIC realization of a bandpass filter using inductance simulation. (b) Practical realization of a bandpass filter using inductance simulation.

A. Frequency Scaling GIC's

The transmission matrix (T) and input impedance ($Z_{in}(s)$) of a GIC are given by

$$T = \begin{bmatrix} 1 & 0 \\ 0 & \frac{Z_2Z_4}{Z_1Z_3} \end{bmatrix} \quad Z_{in}(s) = \frac{V_{in}(s)}{I_{in}(s)} = \frac{Z_1Z_3}{Z_2Z_4} \frac{V_2(s)}{I_2(s)} \quad (23)$$

where impedances Z_1 , Z_2 , Z_3 , and Z_4 are shown in Fig. 3(a). Now if $Z_{in}(s)$ is to be frequency scaled by periodically switched conductances, then one or more of Z_1 , Z_2 , Z_3 , and Z_4 must be periodically switched conductances.

The impedances in (23) which must be periodically switched conductances in order to realize a frequency-scaled capacitive impedance, inductive impedance, and FDNR are shown in Table I.

It has been shown in Table I that a GIC can be used to realize a frequency-scaled capacitive impedance, in-

ductive impedance, and FDNR. We shall now consider several examples of practical tunable filters which are realized using these frequency-scaled impedances.

IV. PRACTICAL REALIZATION

Practical verification of the performance predicated for the periodically switched RC -active ladder structures is illustrated by considering several tunable active filters.

A. Tunable Bandpass RC -Active Filter

The purpose is to illustrate our method of frequency scaling a transfer function by the design of a tunable bandpass active filter using periodically switched conductances to frequency scale or tune a conventional GIC realization [13]. Consider the network shown in Fig. 3(b) in which a GIC is used to simulate an inductance in a simple second-order bandpass filter. The transfer function of the network is given by

$$\frac{V_0(s)}{V_{in}(s)} = \frac{\frac{G_s G_4 C_2 s}{G_1 G_3 G_5}}{\frac{C_1 C_2 G_4 s^2}{G_1 G_3 G_5} + \frac{G_s C_2 G_4}{G_1 G_3 G_5} s + 1} \quad (24)$$

which we wish to frequency scale by use of periodically switched conductances. Following the theory of Section II, we find the output is across a capacitance and hence it is only necessary to find those conductances which frequency scale the transfer function. From (24), it is clear by inspection that the continuous conductances G_s , G_1 , and G_3 may be of the form KG_s , KG_1 , and KG_3 to give continuous frequency scaling. Thus the periodically switched conductances are easily identified as $K(t)G_s$, $K(t)G_1$, and $K(t)G_3$. Then the transfer function of this periodically switched network is obtained from (24) and given by

$$\frac{V_0}{V_{in}} \left(\frac{s}{K} \right) = \frac{\frac{G_s G_4 C_2}{G_1 G_3 G_5} \frac{s}{K}}{\frac{C_1 C_2 G_4}{G_1 G_3 G_5} \frac{s^2}{K^2} + \frac{G_s G_4 C_2}{G_1 G_3 G_5} \frac{s}{K} + 1} \quad (25)$$

A practical verification of (24) was obtained by constructing this periodically switched filter as shown in Fig. 3(b). Practical values of circuit elements are given in the design. The switched conductances are realized by connecting two conductances in parallel and switching one in and out of the circuit with an FET switch [18]. A floating FET switch is used, in which a diode is placed in series with the gate as shown in Fig. 3(b), to stop the switching waveform from interfering with the analog voltage being switched. A speed-up capacitor is placed in parallel with the diode to ensure that the FET switches on rapidly.

The frequency response of the bandpass filter was measured for several values of pulsewidth-to-period

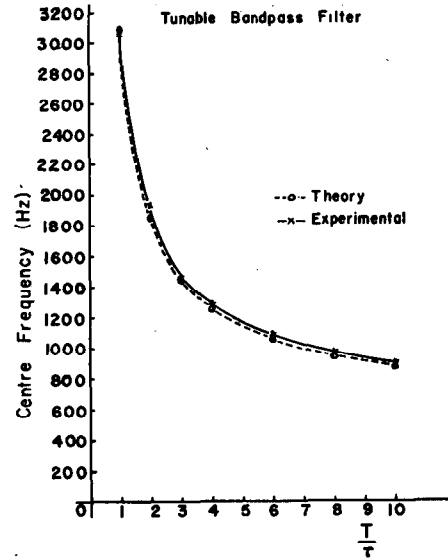
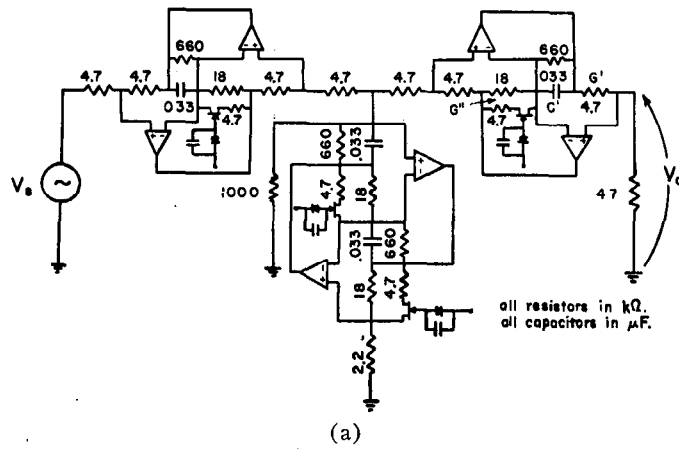

Fig. 4. Center frequency versus T/τ for the tunable bandpass filter.

ratio (τ/T). The value of τ/T was varied by adjusting τ for a constant period T of $12 \mu\text{s}$. The variation of the center frequency of the response of the bandpass response of T/τ in the range 1–10 was measured and appears in Fig. 4 along with the theoretical curve. The theoretical curve was evaluated by calculating the average value of the switched conductances and hence the scaling factor K . The scaling factor was then applied to determine the center frequency at a given value of T/τ , with respect to the value at $T/\tau=1.0$. The bandpass filter was designed to have a Q of 50, and the measured value was 46. The tuning of the center frequency did not affect the Q of the filter. We conclude that a high-quality tunable bandpass active filter may be realized using periodically switched conductances.

B. Tunable Low-Pass RC -Active Ladder Filter

A tunable low-pass ladder filter is considered, where frequency scaling and hence variation of the cutoff frequency, is achieved using periodically switched conductances. A third-order Butterworth low-pass filter is constructed using DCR networks as shown in Fig. 5(a). We have used a version in which the terminating capacitances are simulated using GIC's and the resultant filter is similar to that proposed by Gorski-Popiel [14]. From (22) it is seen that the transfer function of the DCR network is frequency scaled if the impedance of the D element and capacitances are frequency scaled. It has been shown in the preceding section that the input impedance of a GIC may be frequency scaled. Thus a frequency-scaled low-pass filter can be realized as shown in Fig. 6 where two periodically switched conductances realize the D element and one switched conductance is required for each terminating GIC. The nullors in the GIC [Fig. 3(a)] are replaced by operational amplifiers (MCH1439G), and $0.66 \text{ M}\Omega$ resistors



(a)

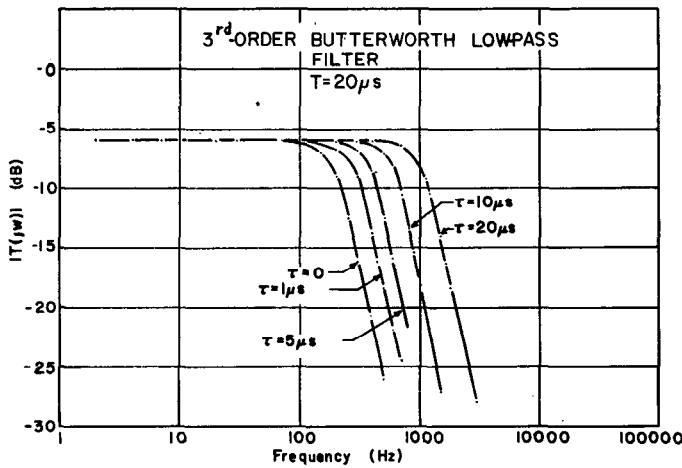

(b)

Fig. 5. (a) Tunable RC-active filter realizing a third-order Butterworth response. (b) Magnitude response of the tunable third-order Butterworth low-pass filter.

not necessary because the network meets the criterion that the output voltage $V_o(t)$ is related to a capacitance voltage $V_c(t)$ across C' via continuous conductances G' and G . (Had we chosen to time vary G' instead of G'' in Fig. 5(a), then the output $V_o(t)$ would require low-pass filtering).

The response of this filter was measured for several pulsewidth-to-period ratios (τ/T) in which τ was varied with a constant $T=12 \mu s$ and is shown in Fig. 5(b). As can be seen, the shape of the response is unaltered by switching, but the network is frequency scaled. The cutoff frequency was measured for T/τ in the range 1-10 and is shown in Fig. 6. The theoretical cutoff frequency is evaluated by calculating the average value of the switched conductances and then using this value to determine the scaling factor K . This scaling factor K is then used to obtain the cutoff frequency of the switched network from its value at $T/\tau=1.0$. It is seen that the theoretical and measured responses are in very good agreement, verifying the preceding method of analysis of periodically switched networks containing GIC's.

This method of tuning ladder filters is particularly attractive because it may clearly be extended to high-order equiterminated structures, where, in general, the time-varying conductances $K(t)G$ may be of identical value. Furthermore, $K(t)$ is identical for each conductance $K(t)G$ because a single timing waveform determines all conductances $K(t)G$. Thus tuning of the filter response by variation of τ/T (and hence K) will not introduce mismatch between the switched conductances. This is a practical advantage because independently adjustable elements, using continuous electronic tuning, require carefully matched nonlinear elements such as analog multipliers [6].

V. CONCLUSIONS

A method of realizing high-quality electronically tunable active filters employing periodically switched conductances is presented. A simple method of analysis of networks containing periodically switched conductances is given and applied to several active-filter realizations. In particular, it is shown that the average input impedance of generalized impedance converters can be frequency scaled by varying the pulsewidth-to-period ratio of periodically switched conductances within the network.

Two practical tunable active ladder filters are considered: a bandpass filter realization employing the inductance simulation methods and a third-order Butterworth low-pass filter realized using the DCR network approach to the design of active ladder structures. The variation of center frequency in the case of the bandpass filter and the cutoff frequency in the case of the low-pass filter as a function of the pulsewidth-to-period ratio (τ/T) is accurately predicted, indicating good agreement between theory and practice. Periodically

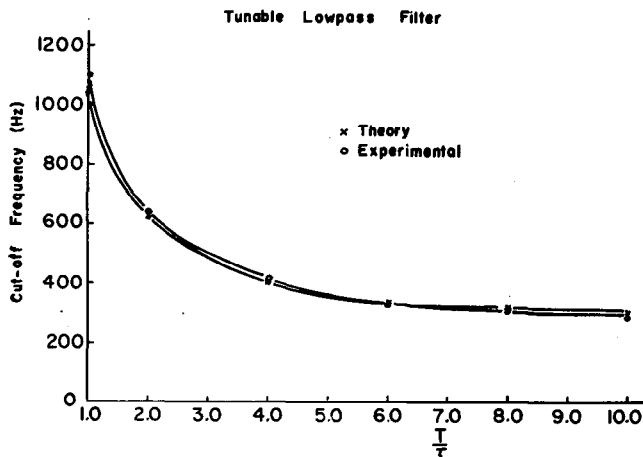

Fig. 6. Cutoff frequency versus T/τ for third-order Butterworth low-pass filter.

have been added in parallel with the capacitors to provide the necessary bias currents for the operational amplifiers. The network is made tunable by periodically switched conductances. The output $V_o(t)$ is across a conductance element G . However, low-pass filtering is

switched conductances provide a means of tuning network functions accurately and should prove to be very useful in low-frequency applications. The possibility now exists to incorporate electronically tunable low-sensitivity ladder structures into adaptive filter systems. Preliminary work has shown that the noise produced by these periodically switched ladder structures is comparable to that of the conventional untuned realization, but the signal-handling capability and hence, dynamic range, is reduced by an amount that is approximately proportional to the ratio K_1/K and therefore the tuning range. It is hoped that further work will reveal the limitations to this method of electronically tuning high-quality RC -active ladder filters.

REFERENCES

- [1] L. E. Franks and I. W. Sandberg, "An alternative approach to the realization of network transfer functions: The N -path filter," *Bell Syst. Tech. J.*, pp. 1321-1350, Sept. 1960.
- [2] J. A. McKinney, "Periodically reverse-switched capacitors," Kansas State Univ., Manhattan, Special Rep. 48, Feb. 1964.
- [3] G. P. Edwards, "Variable bandwidth filters using switching," *Electron. Lett.*, vol. 5, pp. 12-13, Jan. 1969.
- [4] J. A. Kaehler, "Periodic-switched filter networks—A means of amplifying and varying transfer functions," *IEEE J. Solid-State Circuits*, vol. SC-4, pp. 225-230, Aug. 1969.
- [5] F. E. J. Girling and E. F. Good, "Active filters—The two integrator loop," *Wireless World*, pp. 76-80, Feb. 1970.
- [6] L. T. Bruton, "Electronically-tunable analogue active filters," presented at the IEEE Int. Symp. Circuit Theory, London, England, Sept. 1971.
- [7] C. A. Desoer, "Transmission through a linear network containing a periodically operated switch," *WESCON Conf. Rec.* pt. 2, pp. 34-41, 1958.
- [8] I. R. Bashkow, "The A -matrix, New network description," *IRE Trans. Circuit Theory*, vol. CT-4, pp. 117-119, Sept. 1957.
- [9] Y. Sun and I. T. Frisch, "Resistance multiplication in integrated circuits by means of switching," *IEEE Trans. Circuit Theory*, vol. CT-15, pp. 184-192, Sept. 1968.
- [10] L. T. Bruton, "Network transfer functions using the concept of frequency-dependent negative resistance," *IEEE Trans. Circuit Theory*, vol. CT-16, pp. 406-408, Aug. 1969.
- [11] H. J. Orchard, "Inductorless filters," *Electron. Lett.*, vol. 2, pp. 224-225, June 1965.
- [12] R. H. S. Riordan, "Simulated inductance using differential amplifiers," *Electron. Lett.*, vol. 3, pp. 50-51, Feb. 1967.
- [13] A. Antoniou, "Realization of gyrator using operational amplifiers and their use in RC -active network synthesis," *Proc. Inst. Elec. Eng.*, vol. 116, pp. 1838-1850, Nov. 1969.
- [14] J. Gorski-Popiel, " RC -active synthesis using positive imittance converters," *Electron. Lett.*, vol. 3, pp. 381-382, Aug. 1967.
- [15] H. J. Orchard and D. F. Sheahan, "Inductorless bandpass filters," *IEEE J. Solid-State Circuits*, vol. SC-5, pp. 108-118, June 1970.
- [16] W. H. Holmes, S. Gruetzman, and W. E. Heinlein, "Sharp-cut-off filters using floating inductors," *IEEE J. Solid State Circuits*, vol. SC-4, pp. 38-50, Feb. 1969.
- [17] S. K. Mitra, *Analysis and Synthesis of Linear Active Networks*. New York: Wiley, 1968, pp. 36-37.
- [18] J. Eimbinder, *FET Applications Handbook*. Blue Ridge Summit, Pa.: TAB Books.

On the Analysis and Realization of Cascaded Transmission-Line Networks in the Time Domain

KWAME A. BOAKYE AND OMAR WING

Abstract—The time-domain analysis and realization of cascaded, uniform, lossless transmission-line networks are considered. A Hessenberg matrix L is defined in terms of which the reflected impulse response and the transmitted impulse response are expressed in closed form. A realization scheme is presented for determining a network whose reflected impulse response is a specified sequence of impulses.

I. INTRODUCTION

THE TIME-DOMAIN behavior of networks consisting of cascaded sections of uniform, lossless transmission lines is discussed. Such networks

result from equivalent circuit representation in microwave network theory, optics, and acoustics. The analysis and synthesis of these networks have received much attention in the frequency domain [1]–[8], but relatively little in the time domain [9], [10], [13], [14].

Here, by using signal flow graph techniques, the coefficients of the time-domain system functions are obtained, in closed form, as a function of the local scattering parameters. Specifically, given the characteristic impedances of the lines, the reflected impulse response is shown to be a sequence of impulses whose strengths are determined iteratively or in closed form from a certain upper Hessenberg matrix L , and the transmitted impulse response is also a sequence of impulses whose strengths are determined from the transpose of L . Conversely, given a sequence of impulses, a cascaded

Manuscript received May 1, 1972; revised July 26, 1972. This work was supported in part by the National Science Foundation under Grant GK-2228X.

The authors are with the Department of Electrical Engineering and Computer Science, Columbia University, New York, N. Y. 10027.